

PRESSURE RESTRICTING ANGLE HOSE VALVE

MODEL LVPRVA



DESCRIPTION:

The Lansdale Valve Pressure Restricting Valve is a 175 PSI. pressure tested UL/FM Approved valve. Water pressure is controlled by an adjustable flow restriction. If full flow is required, the restriction may be overridden. Furnished with field setting chart.

INSTALLATION:

Refer to the Lansdale's O & M manual.

* Special threads available upon request.

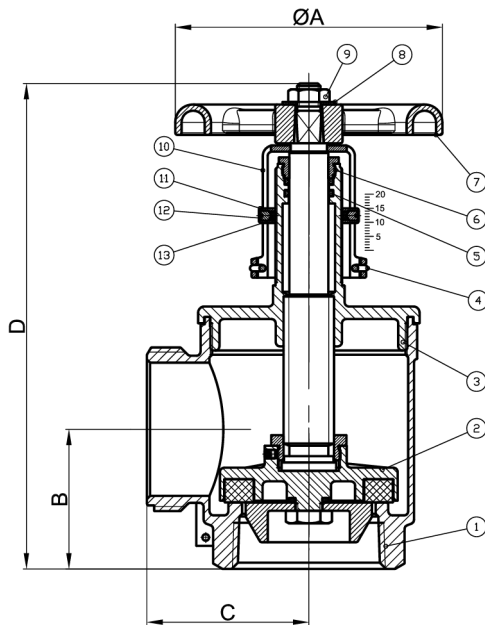

DIMENSIONS (In.)					
INLET	OUTLET	A	B	C	D
2.5" NPT	2.5" NST	5	2.6	3.03	9.1
1.5" NPT	1.5" NST	3.94	1.89	2.44	6.77

MATERIAL SPECIFICATION				
NO.	PART	QTY.	MATERIAL	ASTM SPEC.
1.	Body	1	Forged Brass	C37700
2.	Spool Assembly	1	Forged Brass	C37700
3.	Bonnet	1	Forged Brass	C37700
4.	Wire	1	Stainless Steel	S.S. 304
5.	O-ring	2	Rubber	EPDM
6.	Gland Nut	1	Forged Brass	C37700
7.	Wheel	1	Aluminum Alloy	ZL 102
8.	Washer	1	Stainless Steel	S.S. 304
9.	Wheel Nut	1	Forged Brass	C37700
10.	Setting Indicator	1	Forged Brass	C37700
11.	Collar	1	Forged Brass	C37700
12.	Set Screw	2	Stainless Steel	S.S. 304

PROJECT	APPROVAL STAMP
PROJECT:	<input type="checkbox"/> APPROVED
ADDRESS:	<input type="checkbox"/> APPROVED AS NOTED
ENGINEER:	<input type="checkbox"/> NOT APPROVED
SUBMITTAL DATA:	REMARKS:
NOTES 1:	
NOTES 2:	